

THIS DRAWING IS UNPUBLISHED. RELEASED FOR PUBLICATION, 19
 © COPYRIGHT 19 BY AMP INCORPORATED, HARRISBURG, PA. ALL INTERNATIONAL RIGHTS RESERVED. AMP PRODUCTS MAY BE COVERED BY U.S. AND FOREIGN PATENTS AND/OR PATENTS PENDING.

- 1 GOLD PLATING NOT REQUIRED IN THIS AREA.
- 2 LOOSE PIECE CUT-OFF DIMENSION.
- 3 POINT OF MEASUREMENT FOR PLATING THICKNESS (INSIDE BEAMS)
- 4 .00030 GOLD IN CONTACT AREA, GOLD FLASH ON REMAINDER OF TERMINAL, ALL OVER .00050 NICKEL.
- 5 .000100+.000200 BRIGHT TIN-LEAD OVER .00050 NICKEL.
- 6 POINT OF MEASUREMENT FOR PLATING THICKNESS (INSIDE BARREL)
- 7 OBSOLETE PART NO.

REVISIONS					
P	F	ZONE	LTR	DESCRIPTION	DATE APPROVED
0	✓		D	RELEASED	
01	✓		01	REV PER ECN 708	WBL 6-24-88 JGH
02	✓		02	REV ECN 980	Hm 3-24-88 JCG
A	✓		A	REVECN AR2029	DK 9-28-88 JCG
B	✓		B	REV ECN AR2149	D/K 10-31-88 JCG
C	✓		C	REV LOC & DIST AD-4171	11-27-89 BF
D	✓		D	REV PER AD-5350	2-10-91 JLG
E	✓		E	OBS -4 PER 0010-0976-93	1-13-93 JH/PS
F	✓		F	REV PER 0010-0312-96	1-21-97 CB/JS

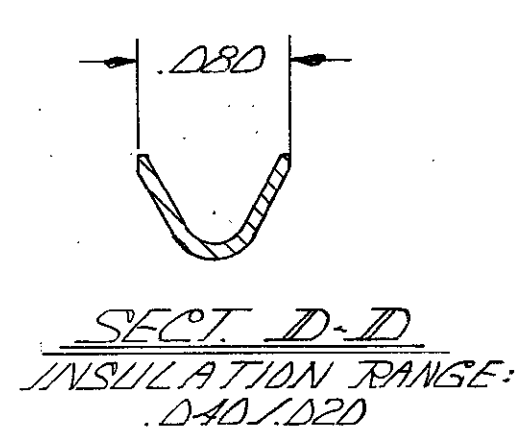
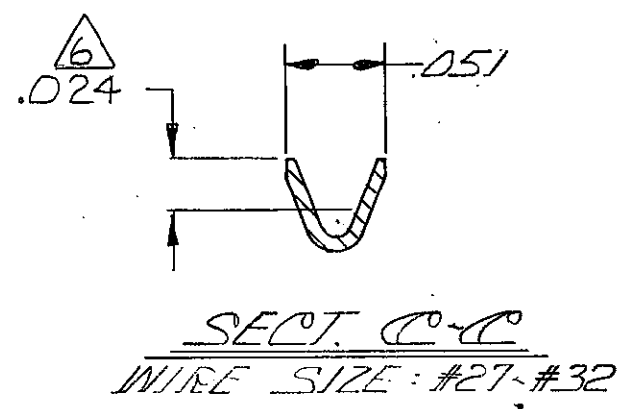
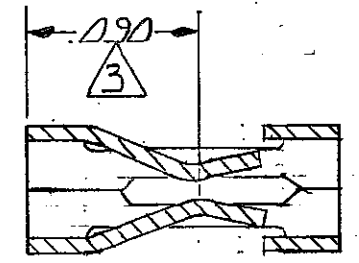
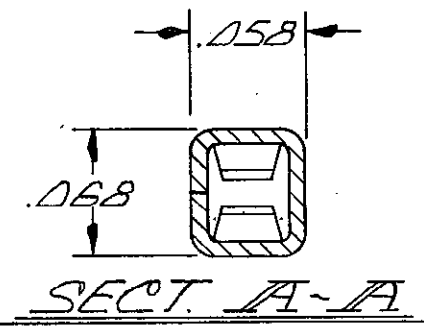
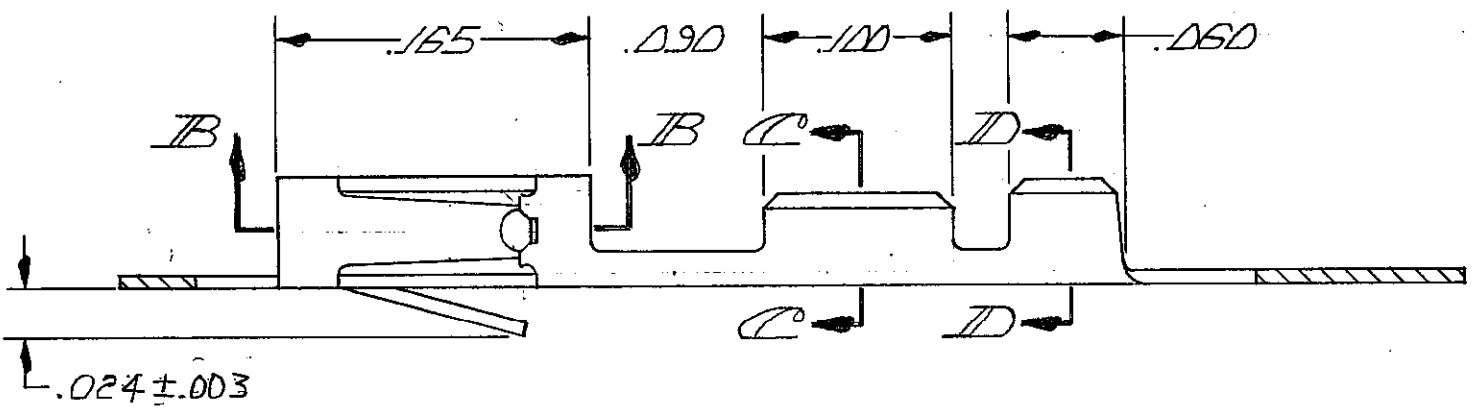
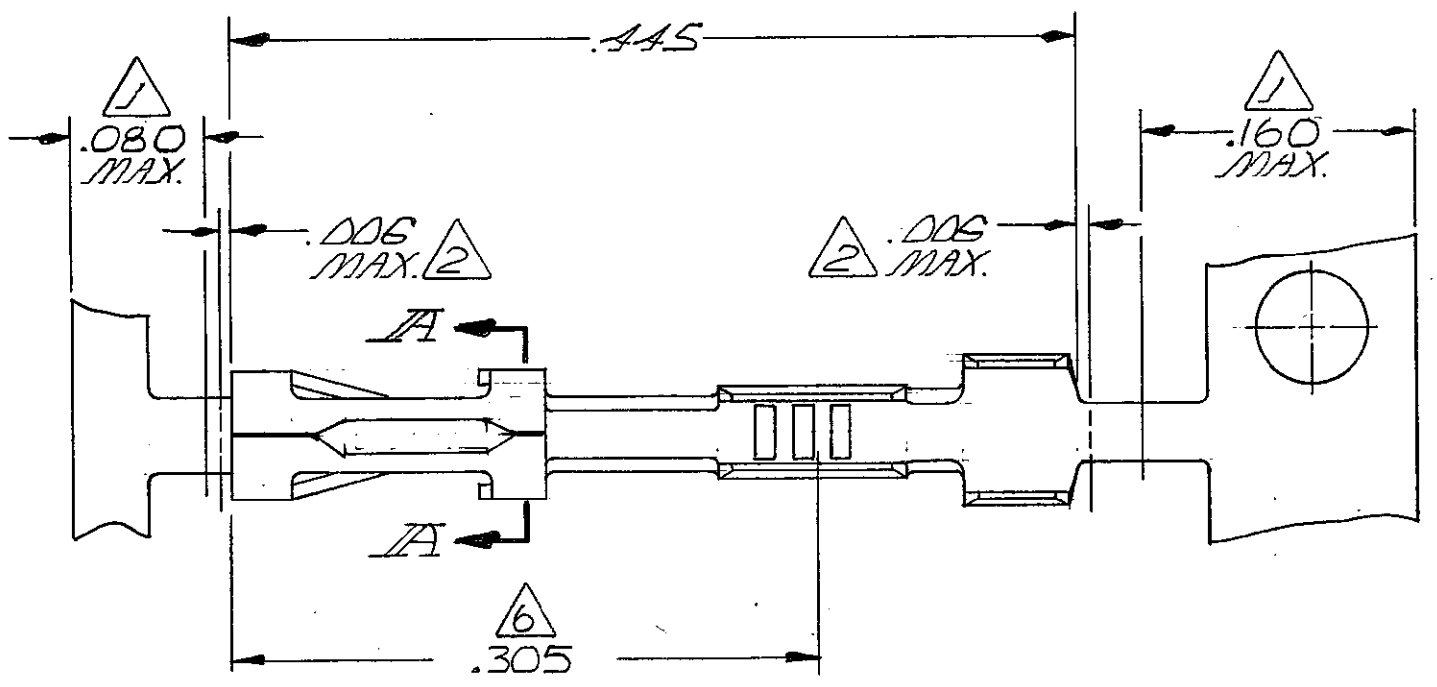

7	5	13	AD3455-4
		A	AD3455-1
LOOSE PIECE	FINISH	PART NO	
PART NO			

UNLESS OTHERWISE SPECIFIED DIMENSIONS ARE IN INCHES. TOLERANCES ON: DECIMALS ± .005 ANGLES ±	CONTRACT NO	AMP AMP INCORPORATED Harrisburg, Pa. 17105	
	DR <i>[Signature]</i>		
MATERIAL PHOS. BRONZE, .008 THICK.	CHK <i>[Signature]</i> 6/08/84	SIZE C	FSCM NO 00779
FINISH SEE TABLE	APPD <i>[Signature]</i> 7/2/84	DRAWING NO 103455	
	DSGN APPD <i>[Signature]</i> 7/12/84	SCALE 10:1	SHEET 1 OF 1
	OTHER APPD	CUSTOMER DRAWING	

103455